

PHYSICS (Theory)

Time allowed : 3 hours

Maximum Marks : 70

General Instructions:

- (i) All questions are compulsory.
- (ii) There are 30 questions in total. Questions 1 to 8 carry one mark each, questions 9 to 18 carry two marks each, questions 19 to 27 carry three marks each and questions 28 to 30 carry five marks each.
- (iii) There is no overall choice. However, an internal choice has been provided in one question of two marks, one question of three marks and all three questions of five marks each. You have to attempt only one of the choice in such questions.
- (iv) Use of calculators is **not** permitted.
- (v) You may use the following values of physical constants wherever necessary:

$$c = 3 \times 10^8 \text{ ms}^{-1}$$

$$h = 6.626 \times 10^{-34} \text{ Js}$$

$$e = 1.602 \times 10^{-19} \text{ C}$$

$$\mu_0 = 4\pi \times 10^{-7} \text{ TmA}^{-1}$$

$$\frac{1}{4\pi\epsilon_0} = 9 \times 10^9 \text{ Nm}^2\text{C}^{-2}$$

$$\text{Mass of electron } m_e = 9.1 \times 10^{-31} \text{ kg}$$

$$\text{Mass of neutron } m_n = 1.675 \times 10^{-27} \text{ kg}$$

$$\text{Boltzmann's constant } k = 1.381 \times 10^{-23} \text{ JK}^{-1}$$

$$\text{Avogadro's number } N_A = 6.022 \times 10^{23} \text{ mol}^{-1}$$

$$\text{Radius of earth} = 6400 \text{ km}$$

QUESTION PAPER CODE 51/1/1

1. In which orientation, a dipole placed in a uniform electric field is in (i) stable, (ii) unstable equilibrium? 1
2. Which part of electromagnetic spectrum has largest penetrating power? 1
3. A plot of magnetic flux (ϕ) versus current (I) is shown in the figure for two inductors A and B. Which of the two has larger value of self inductance? 1

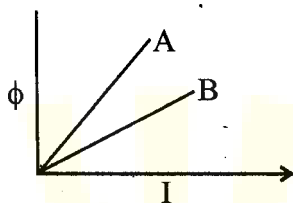

4. Figure shows three point charges, $+2q$, $-q$ and $+3q$. Two charges $+2q$ and $-q$ are enclosed within a surface 'S'. What is the electric flux due to this configuration through the surface 'S'? 1

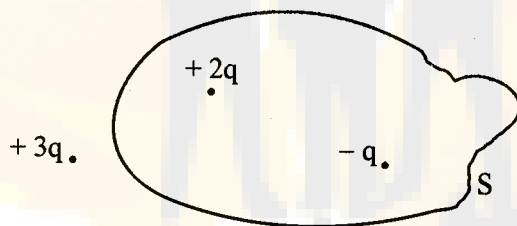

5. A glass lens of refractive index 1.45 disappears when immersed in a liquid. What is the value of refractive index of the liquid? 1
6. What is the ratio of radii of the orbits corresponding to first excited state and ground state in a hydrogen atom? 1
7. A wire of resistance $8R$ is bent in the form of a circle. What is the effective resistance between the ends of a diameter AB? 1

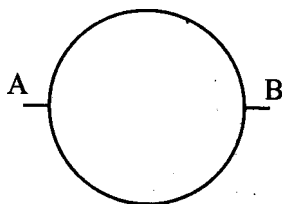

8. State the conditions for the phenomenon of total internal reflection to occur. 1
9. Explain the function of a repeater in a communication system. 2
10. (i) Write two characteristics of a material used for making permanent magnets. 2
(ii) Why is core of an electromagnet made of ferromagnetic materials ?

OR

Draw magnetic field lines when a (i) diamagnetic, (ii) paramagnetic substance is placed in an external magnetic field. Which magnetic property distinguishes this behaviour of the field lines due to the two substances ?

11. Draw the circuit diagram of an illuminated photodiode in reverse bias. How is photodiode used to measure light intensity ? 2
12. An electric lamp having coil of negligible inductance connected in series with a capacitor and an AC source is glowing with certain brightness. How does the brightness of the lamp change on reducing the (i) capacitance, and (ii) the frequency ? Justify your answer. 2

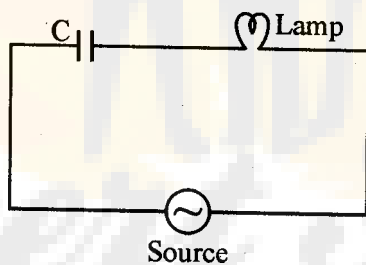

13. Arrange the following electromagnetic radiations in ascending order of their frequencies : 2
- (i) Microwave
(ii) Radio wave
(iii) X-rays
(iv) Gamma rays

Write two uses of any one of these.

14. The radii of curvature of the faces of a double convex lens are 10 cm and 15 cm. If focal length of the lens is 12 cm, find the refractive index of the material of the lens. 2
15. An electron is accelerated through a potential difference of 100 volts. What is the de-Broglie wavelength associated with it? To which part of the electromagnetic spectrum does this value of wavelength correspond? 2
16. A heavy nucleus X of mass number 240 and binding energy per nucleon 7.6 MeV is split into two fragments Y and Z of mass numbers 110 and 130. The binding energy of nucleons in Y and Z is 8.5 MeV per nucleon. Calculate the energy Q released per fission in MeV. 2
17. (a) The bluish colour predominates in clear sky. 2
(b) Violet colour is seen at the bottom of the spectrum when white light is dispersed by a prism.
State reasons to explain these observations.
18. Plot a graph showing the variation of stopping potential with the frequency of incident radiation for two different photosensitive materials having work functions W_1 and W_2 ($W_1 > W_2$). On what factors does the (i) slope and (ii) intercept of the lines depend? 2
19. A parallel plate capacitor is charged by a battery. After sometime the battery is disconnected and a dielectric slab with its thickness equal to the plate separation is inserted between the plates. How will (i) the capacitance of the capacitor, (ii) potential difference between the plates and (iii) the energy stored in the capacitor be affected?
Justify your answer in each case. 3
20. Write the principle of working of a potentiometer. Describe briefly, with the help of a circuit diagram, how a potentiometer is used to determine the internal resistance of a given cell. 3
21. Write the expression for the magnetic moment (\vec{m}) due to a planar square loop of side 'l' carrying a steady current I in a vector form.

In the given figure this loop is placed in a horizontal plane near a long straight conductor carrying a steady current I_1 at a distance l as shown. Give reasons to explain that the loop will experience a net force but no torque. Write the expression for this force acting on the loop.

3

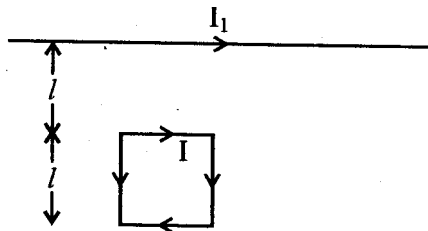

22. (a) Depict the equipotential surfaces for a system of two identical positive point charges placed a distance 'd' apart.

(b) Deduce the expression for the potential energy of a system of two point charges q_1 and q_2 brought from infinity to the points \vec{r}_1 and \vec{r}_2 respectively in the presence of external electric field \vec{E} .

3

23. What is an unpolarized light ? Explain with the help of suitable ray diagram how an unpolarized light can be polarized by reflection from a transparent medium. Write the expression for Brewster angle in terms of the refractive index of denser medium.

3

24. (i) Define 'activity' of a radioactive material and write its S.I. unit.

(ii) Plot a graph showing variation of activity of a given radioactive sample with time.

(iii) The sequence of stepwise decay of a radioactive nucleus is

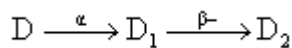

If the atomic number and mass number of D_2 are 71 and 176 respectively, what are their corresponding values for D ?

3

25. A long straight wire of a circular cross-section of radius 'a' carries a steady current 'I'. The current is uniformly distributed across the cross-section. Apply Ampere's circuital law to calculate the magnetic field at a point 'r' in the region for (i) $r < a$ and (ii) $r > a$.

3

OR

State the underlying principle of working of a moving coil galvanometer. Write two reasons why a galvanometer can not be used as such to measure current in a given circuit. Name any two factors on which the current sensitivity of a galvanometer depends.

26. What is space wave propagation ? Give two examples of communication system which use space wave mode.

A TV tower is 80 m tall. Calculate the maximum distance upto which the signal transmitted from the tower can be received.

3

27. In a meter bridge, the null point is found at a distance of 40 cm from A. If a resistance of $12\ \Omega$ is connected in parallel with S, the null point occurs at 50.0 cm from A. Determine the values of R and S.

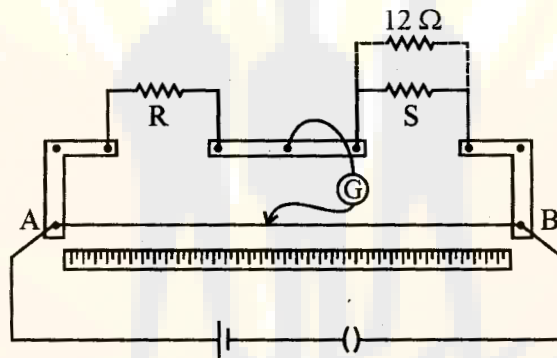

28. Describe briefly, with the help of a labelled diagram, the basic elements of an A.C. generator. State its underlying principle. Show diagrammatically how an alternating emf is generated by a loop of wire rotating in a magnetic field. Write the expression for the instantaneous value of the emf induced in the rotating loop.

5

OR

A series LCR circuit is connected to an ac source having voltage $v = v_m \sin \omega t$. Derive the expression for the instantaneous current I and its phase relationship to the applied voltage.

Obtain the condition for resonance to occur. Define 'power factor'. State the conditions under which it is (i) maximum and (ii) minimum.

29. State Huygens's principle. Show, with the help of a suitable diagram, how this principle is used to obtain the diffraction pattern by a single slit.

Draw a plot of intensity distribution and explain clearly why the secondary maxima become weaker with increasing order (n) of the secondary maxima.

5

OR

Draw a ray diagram to show the working of a compound microscope. Deduce an expression for the total magnification when the final image is formed at the near point.

In a compound microscope, an object is placed at a distance of 1.5 cm from the objective of focal length 1.25 cm. If the eye piece has a focal length of 5 cm and the final image is formed at the near point, estimate the magnifying power of the microscope.

30. (a) Explain the formation of depletion layer and potential barrier in a p-n junction.
 (b) In the figure given below the input waveform is converted into the output waveform by a device 'X'. Name the device and draw its circuit diagram.

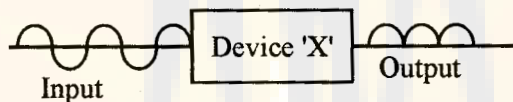

- (c) Identify the logic gate represented by the circuit as shown and write its truth table.

5

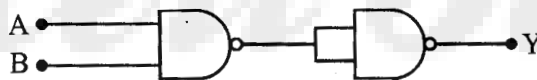

OR

- (a) With the help of the circuit diagram explain the working principle of a transistor amplifier as an oscillator.
 (b) Distinguish between a conductor, a semiconductor and an insulator on the basis of energy band diagrams.